

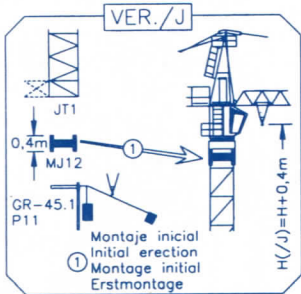

COMANSA

NT - 45120

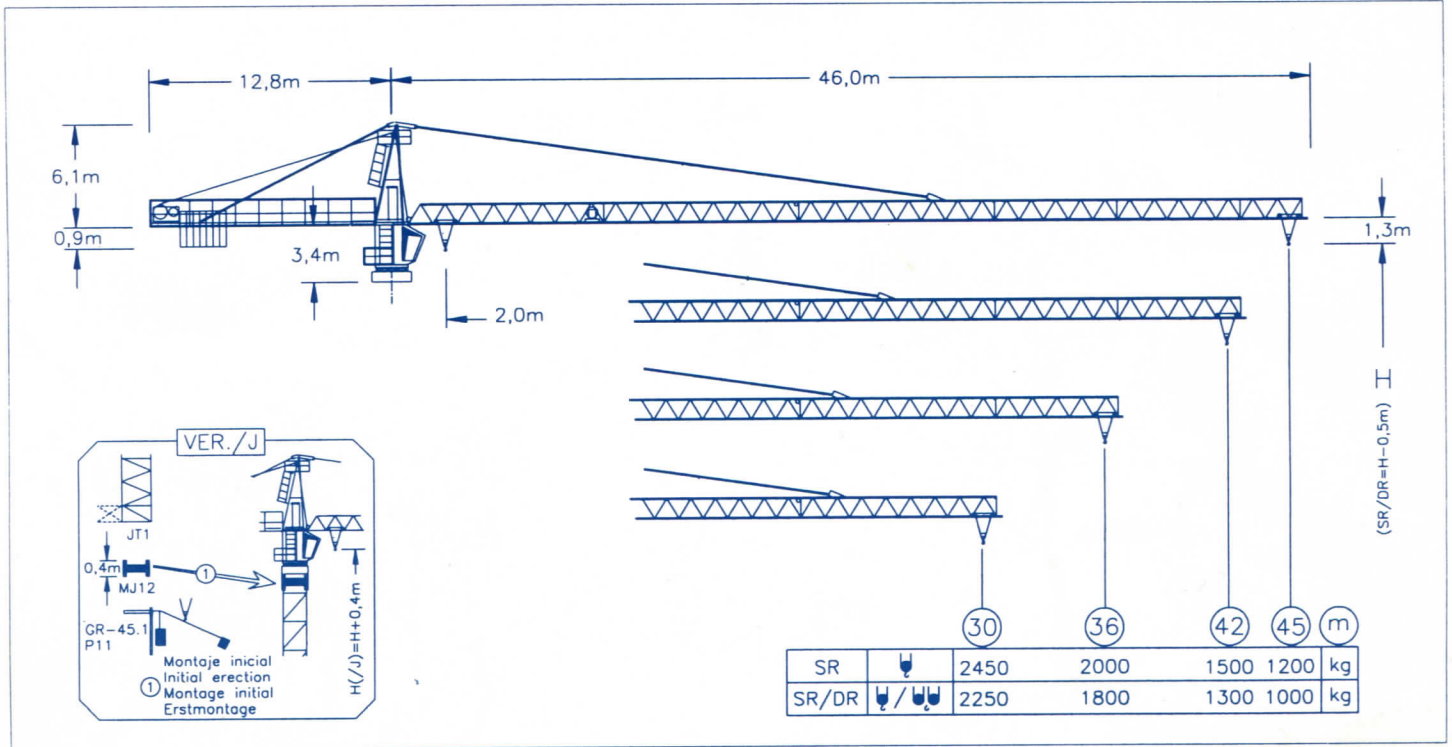

SR		2450	2000	1500	1200	kg
SR/DR		2250	1800	1300	1000	kg

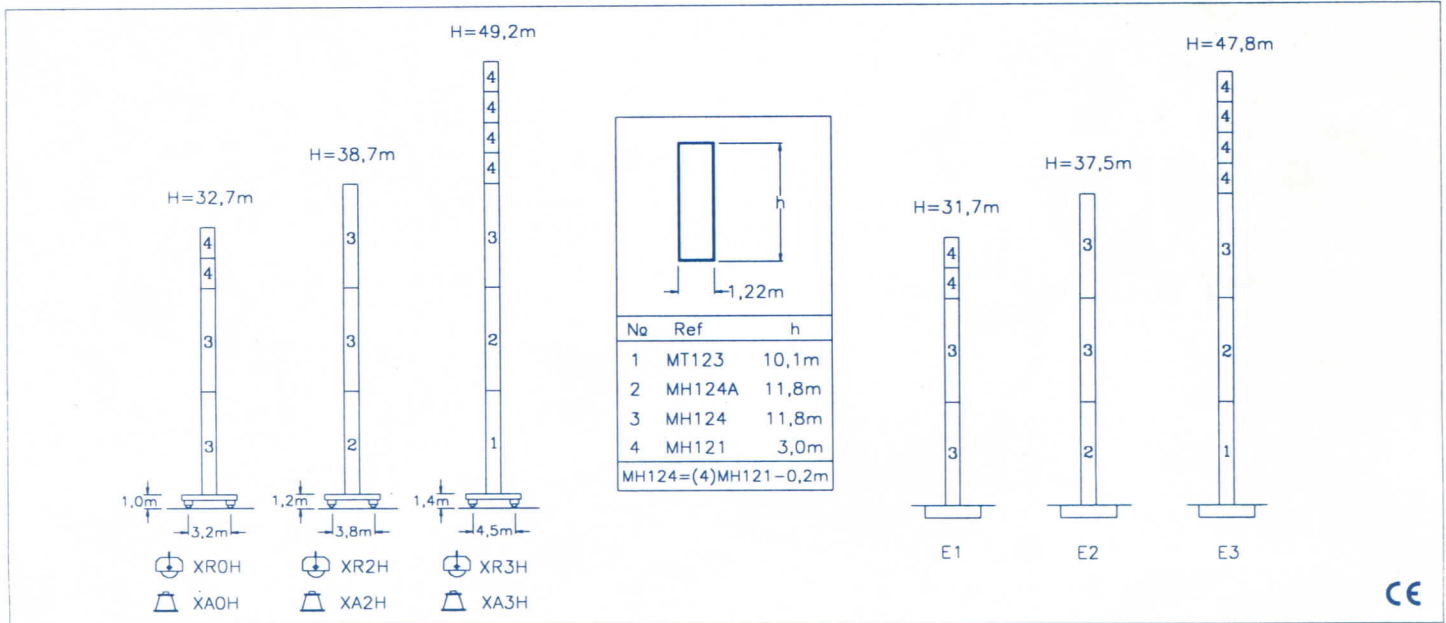

CE

Ⓡ	R(Cmax)	C(max)	18	21	24	27	30	33	36	39	42	45m	
45	SR	23.8m	2500	2500	2500	2480	2180	1930	1730	1560	1420	1300	1200kg
	SR/DR	12.0m	5000	3140	2620	2240	1940	1700	1510	1350	1210	1100	1000kg
42	SR	26.8m	2500	2500	2500	2500	2480	2210	1980	1790	1630	1500kg	
	SR/DR	13.6m	5000	3620	3030	2590	2250	1980	1760	1580	1430	1300kg	
36	SR	29.5m	2500	2500	2500	2500	2500	2460	2210	2000kg			
	SR/DR	15.0m	5000	4070	3410	2920	2540	2240	2000	1800kg			
30	SR	29.5m	2500	2500	2500	2500	2500	2450kg					
	SR/DR	15.0m	5000	4070	3410	2930	2550	2250kg					

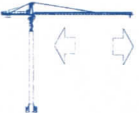

CS2-1.9
1.9 kW

14 m/mn
42

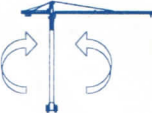

GR-7.5
75 Nm

0 ⇄ 0.16
0.16 ⇄ 0.4 rpm
0.4 ⇄ 0.8



ES3-18-12
18 kW

		I	II	III
SR	m/min	8	35	70
	kg	2500	2500	1300
DR	m/min	4	17.5	35
	kg	5000	5000	2600



TS2-3.0	TS2-4.5	TS2-5.5
2x30Nm	2x45Nm	2x55Nm
0 ⇄ 20 m/mn		
XR0H	XR2H	XR3H

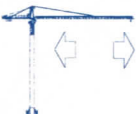

CFU-2.2
2.2 kW

0 ⇄ 75 2,5 t
0 ⇄ 45 5,0 t

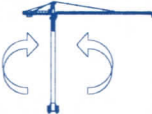

GFU-7.5
75 Nm

0 ⇄ 0.14
0.14 ⇄ 0.35 rpm
0.35 ⇄ 0.8

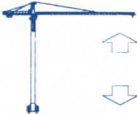

EFU2-18-12 (18 kW)

SR



DR



Tensión de alimentación Operating voltage Tension de service Betriebsspannung	380 V 3 ph 50 Hz
--	---

R máx.	En servicio In service En service In betrieb	XR0H 37,3 t XR2H 37,7 t XR3H 42,1 t
---------------	---	---

Sección de cable Cross section of cable Section du câble Kabelquerschnitt	4 x 25 mm²
--	------------------------------

R máx.	Fuera de servicio Out of service Hors service Ausser Betrieb	XR0H 40,4 t XR2H 44,7 t XR3H 63,9 t
---------------	---	---

Potencia total de motores Total motor output Puissance totale des moteurs Gesamtmotorenleistung	XR0H ... 26,6 kW XR2H ... 28,0 kW XR3H ... 29,0 kW
--	---

Peso de la construcción Dead weight Poids de la construction Konstruktionsgewicht	XR0H 19,7 t XR2H 21,5 t XR3H 27,3 t
--	---

OPCIONAL OPTIONAL EN OPTION KAUFOPTION	*
---	----------

Lastre de base Base ballast Lest base Zentralballast	XR0H 47,6 t XR2H 42,3 t XR3H 54,0 t
---	---



Polígono Industrial de Areta
31620 Huarte-Pamplona (Navarra) ESPAÑA
Teléf. (9)48 - 33 50 20
Fax (9)48 - 33 08 10
Apartado Postal (P. O. Box) 1239
31080 Pamplona (Navarra) ESPAÑA